

INTERFACE & INTERCONNECTION FOR 4-INCH & 6-INCH TFT / LCDs

Alan Dragon, Field Applications Engineer

INTRODUCTION

Sharp Electronics Corporation has introduced a series of small TFT (Thin Film Transistor) LCD modules to be used in a wide range of video applications. These displays are well suited for use in Portable TV/VCR Entertainment Systems, Test/Control Equipment, Control and Entertainment displays for Aviation, along with Automotive, Navigational and Imaging Applications. The current product line-up includes diagonal sizes of 3", 4" and 5.7" (Table 2, page 2). With three formats available (234V x 32.5H, 234V x 720H, 240V x 720H), NTSC and PAL Video Standards can be supported by various models within the product line (Note 1). All 4" and 5.7" models are available with a 6 o'clock or a 12 o'clock viewing direction for optimum performance with any mounting orientation.

Sharp TFT LCDs use the normally white mode of operation for an excellent contrast ratio and superior color reproducibility. This is characterized by a contrast ratio of 30:1 with a light output of 120 nits (35 foot-lamberts). With these specifications, the TFT LCD modules can be used in various lighting environments.

The possibility of battery operation is enhanced by the low power consumption of the TFT display. Total power is typically 2.6 watts, with 1.7 watts of that total being consumed by the backlight.

VIDEO SIGNAL STANDARDS

NTSC/PAL

It will be useful to understand the video standards of NTSC and PAL before explaining the actual interface of the TFT displays. NTSC (National Television System Committee) and PAL (Phase Alternation Line) are two different color encoding methods for broadcasting or sending color video information. Most countries around the world have adopted one of these two standards. The remaining countries have adopted SECAM, which is based on the PAL Standard (Table 3). This application note will concentrate on the timing characteristics of the NTSC and PAL Standards and leave the explanation of color encoding and decoding methods up to video textbooks.

Note 1: The current product line reflects improvements made to earlier models (Table 1).

Table 1.
Transition from Prototype Models to Current Production Models

CURRENT MODEL	PROTOTYPE MODEL
LQ4RE01 NTSC/PAL 6 o'clock	LQ424Y02 [NTSC 6 o'clock] LQ424P01 [PAL 6 o'clock]
LQ4RA01 NTSC/PAL 6 o'clock	LQ424A01 [NTSC 6 o'clock] LQ6MA01 [PAL 6 o'clock]
LQ4RE02 NTSC/PAL 12 o'clock	LQ4NA02 [NTSC 12 o'clock] LQ4MA02 [PAL 12 o'clock]
LQ6RA01 NTSC/PAL 6 o'clock	LQ6NA01 [NTSC 6 o'clock] LQMA01 [PAL 6 o'clock]
LQ6RA02 NTSC/PAL 12 o'clock	LQ6NA01 [NTSC 12 o'clock] LQ6MA02 [PAL 12 o'clock]
LQ6RA02 NTSC/PAL 12 o'clock	LQ6NA02 [NTSC 12 o'clock] LQ6MA02 [PAL 12 o'clock]

The basic difference between NTSC and PAL is the number of lines per frame. NTSC uses 525 lines per frame at a 60 Hz field rate and PAL uses 625 lines per frame at a 50 Hz field rate (Table 4).

When an image is broken up into more horizontal lines, the resolution and image quality improve accordingly. Both standards consist of two interlaced fields. These two fields (designated odd and even) make up one full frame. The alternating odd and even fields make the actual frame rate 1/2 of the field rate (Figure 1). Although the two fields alternate, the human eye will superimpose and blend the odd and even fields to give the appearance of one continuous and flicker-free image.

Table 2.
Sharp's Small TFT Color LCD Modules

MODEL	DIAGONAL SCREEN SIZE (INCHES)	PIXEL FORMAT (V x H)	INPUT CAPABILITY	BACKLIGHT	VIEWING DIRECTION	EFFECTIVE VIEWING AREA (W x H) (mm)	DOT PITCH (W x H) (mm)	OUTLINE DIMENSIONS (W x H x L) (mm)	WEIGHT (GRAMS)	INTERFACE
LQ4RE01	4	234 x 479	NTSC/PAL	N/A	6 o'clock	81.9 x 61.8	0.171 x 0.264	122 x 100 x 6.6	135	N/A
LQ4RE02	4	234 x 479	NTSC/PAL	N/A	12 o'clock	81.9 x 61.8	0.171 x 0.264	122 x 100 x 6.6	135	N/A
LQ4RA01	4	234 x 479	NTSC/PAL	HCFT/Built-in	6 o'clock	81.9 x 61.8	0.171 x 0.264	110.2 x 85.8 x 20.7	170	Analog RGB
LQ4RA02	4	234 x 479	NTSC/PAL	HCFT/Built-in	12 o'clock	81.9 x 61.8	0.171 x 0.264	110.2 x 85.8 x 20.7	170	Analog RGB
LQ4NC01	4	234 x 479	NTSC	HCFT/Built-in	6 o'clock	81.9 x 61.8	0.171 x 0.264	110.2 x 85.8 x 20.7	180	Composite/Analog RGB
LQ4NC02	4	234 x 479	NTSC	HCFT/Built-in	12 o'clock	81.9 x 61.8	0.171 x 0.264	110.2 x 85.8 x 20.7	180	Composite/Analog RGB
LQ6RA01	5.7	240 x 720	NTSC/PAL	CCFT/Built-in	6 o'clock	113.8 x 87.6	0.158 x 0.365	149.4 x 117 x 23	310	Analog RGB
LQ6RA02	5.7	240 x 720	NTSC/PAL	CCFT/Built-in	12 o'clock	113.8 x 87.6	0.158 x 0.365	149.4 x 117 x 23	310	Analog RGB
LQ6NC01	5.7	240 x 720	NTSC	CCFT/Built-in	6 o'clock	113.8 x 87.6	0.158 x 0.365	149.4 x 117 x 23	320	Composite/Analog RGB
LQ6NC02	5.7	240 x 720	NTSC	CCFT/Built-in	12 o'clock	113.8 x 87.6	0.158 x 0.365	149.4 x 117 x 23	320	Composite/Analog RGB
LQ6MC01	5.7	240 x 720	PAL	CCFT/Built-in	6 o'clock	113.8 x 87.6	0.158 x 0.365	149.4 x 117 x 23	320	Composite/Analog RGB
LQ6MC02	5.7	240 x 720	PAL	CCFT/Built-in	12 o'clock	113.8 x 87.6	0.158 x 0.365	149.4 x 117 x 23	320	Composite/Analog RGB
LQ323Y11	3	234 x 382.5	NISC	N/A	6 o'clock	61.7 x 44.5	0.161 x 0.190	94.2 x 78.5 x 61	80	N/A
LQ323P07	3	234 x 382.5	PAL	N/A	6 o'clock	61.7 x 44.5	0.161 x 0.190	94.2 x 78.5 x 61	80	N/A

Note: All specifications are subject to change.

Table 3. International Television Standards

LINES PER FRAME: 525 FIELD RATE: 60 Hz COLOR CODING: NTSC	LINES PER FRAME: 625 FIELD RATE: 50 Hz COLOR CODING: PAL	LINES PER FRAME: 625 FIELD RATE: 50 Hz COLOR CODING: SECAM
Antiqua, West Indies	Algeria	Afars and Issas
Bahamas	Australia	Arab Republic of Egypt
Barbados	Austria	Bulgaria
British Virgin Islands	Bahrain	Czechoslovakia
Canada	Bangladesh	East Germany
Chile	Brunei	France
Costa Rica	Brazil (525/60)	Greece
Cuba	Denmark	Haiti
Dominican Republic	Federal Republic of Germany	Hungary
Ecuadoron Republic	Finland	Iran
El Salvador	Hong Kong	Ivory Coast
Guatemala	Iceland	Iraq
Japan	Ireland	Lebanon
Mexico	Italy	Luxembourg
Netherlands Antiles, West Indies	Jordan	Mauritius
Nicaragua	Kuwait	Monaco
Panama	Malaysia	Morocco
Peru	Netherlands	Poland
Phillipines	New Zealand	Reunion
St. Kitts, West Indies	Nigeria	Saudi Arabia
Samoa (U.S.)	Norway	Tunisia
Surinam	Oman	USSR
Province of Taiwan	Pakistan	Zaire
Trinidad, West Indies	Oatar	
Trust Territory of Pacific	Singapore	
United States of America	South Africa	
	Spain	
	Sweden	
	Switzerland	
	Tanzania	
	Thailand	
	Turkey	
	United Arab Emirates	
	United Kingdom	
	Yugoslavia	

Table 4. NTSC and PAL Timing Standards

NTSC	PAL
Lines / Frame: 525	Lines / Frame: 625
Lines / Field: 262.5	Lines / Field: 312.5
Field Rate: 60 Hz	Field Rate: 50 Hz
Frame Rate: 30 Hz	Frame Rate: 25 Hz
Display Period: 24 OH	Display Period: 28 OH
Horizontal Interval: 63.5 μ s (1H)	Horizontal Interval: 64.0 μ s (1H)
Vertical Interval: 16.7 ms (262.5H)	Vertical Interval: 20.0 ms (312.5H)
Vertical Blanking: 1.42 ms (22.5H)	Vertical Blanking: 2.08 ms (32.5H)
Vertical Sync Pulse: 254 μ s (4H)	Vertical Sync Pulse: 256 μ s (4H)

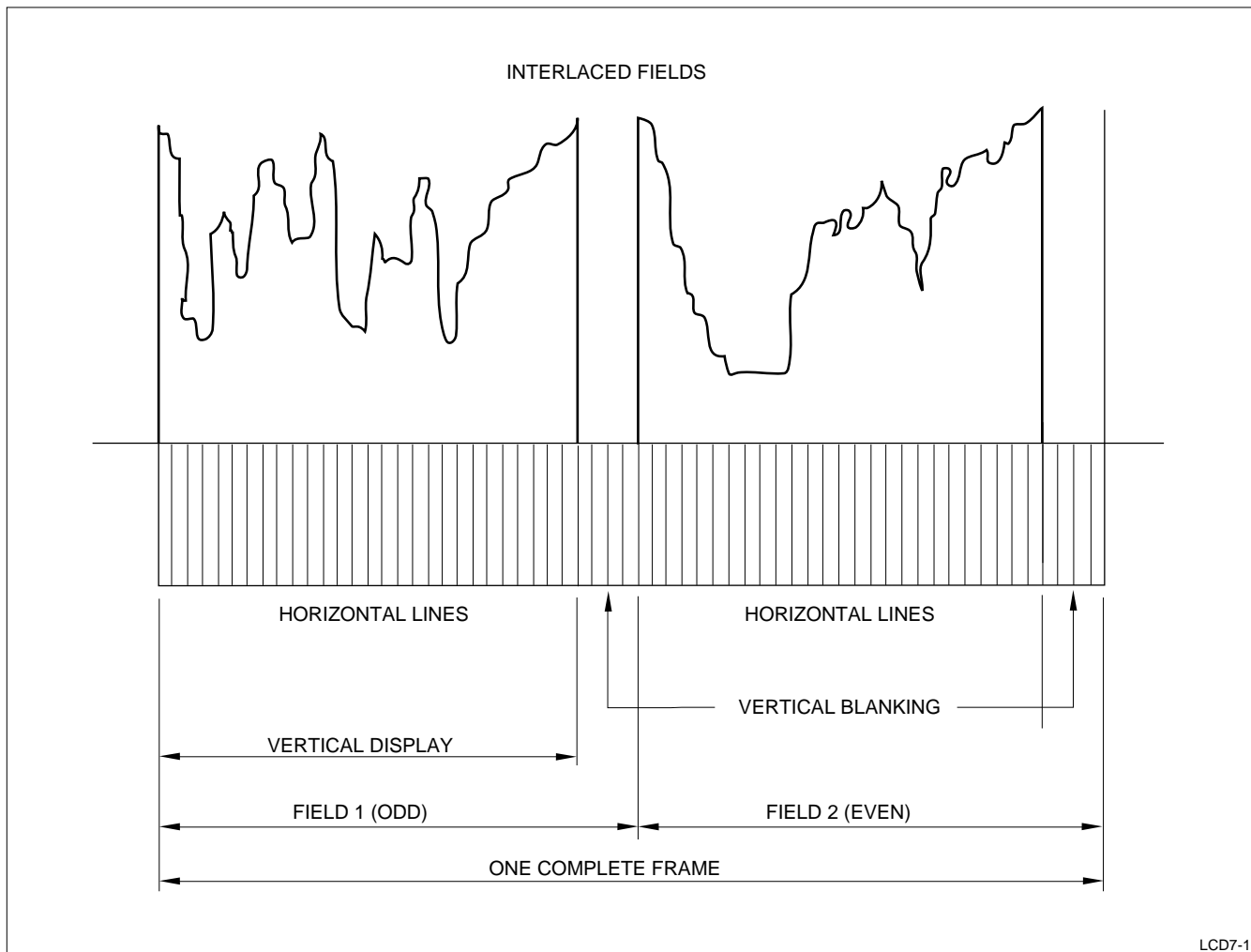

Fig. 1. Interlaced Fields

Composite/Non-Composite Video Signals

Video signals can be transmitted in a variety of formats. Sharp TFT LCD modules will support the following video configuration:

- Composite Video - Video information is combined with horizontal and vertical sync and color burst information into one signal (Figure 2).
- Analog RGB (non-composite)- Separate red, green and blue video signals used in conjunction with composite sync or separate horizontal and vertical sync (Figure 3).
- Composite Sync - Horizontal and vertical sync are combined into one signal (Figure 4).

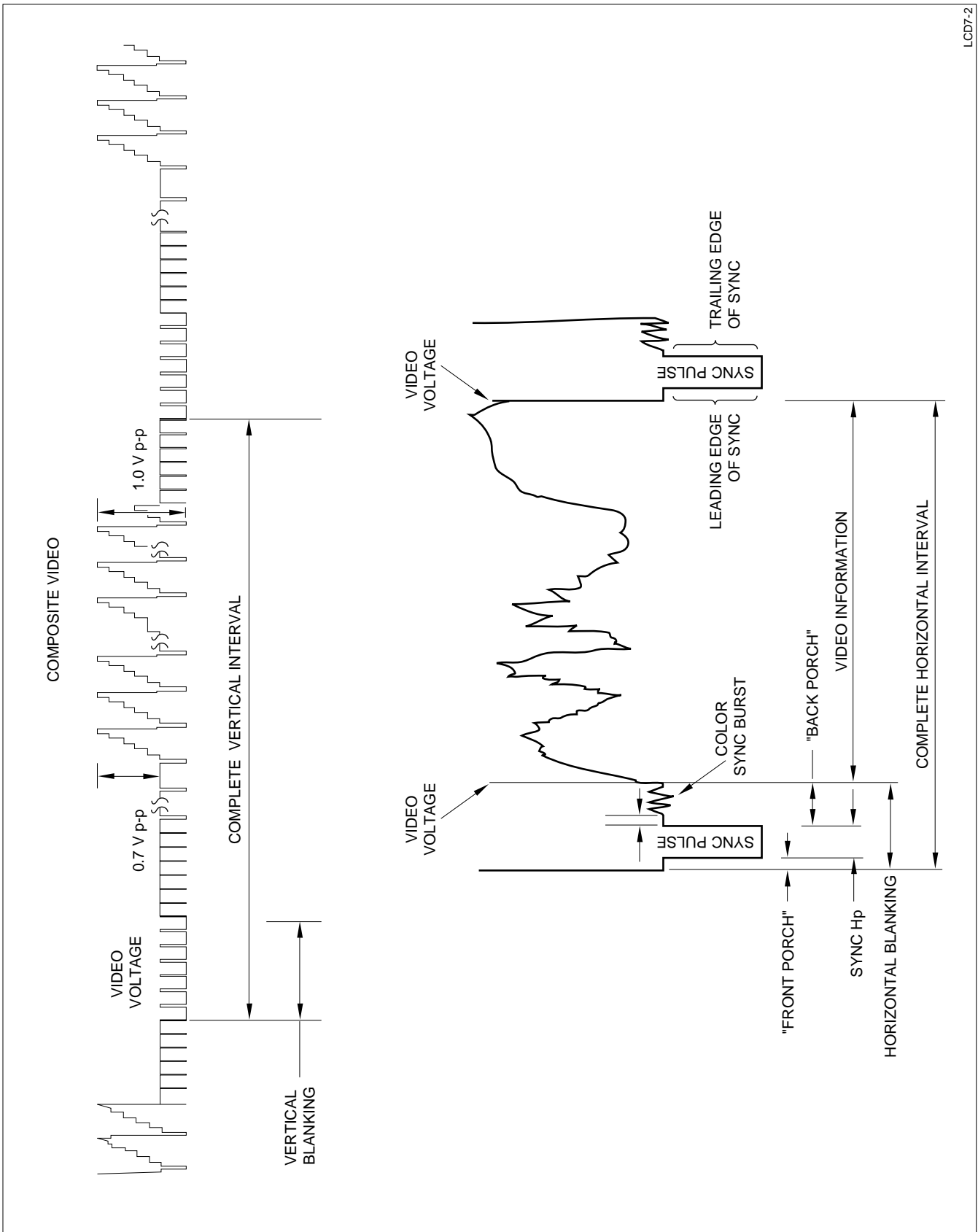

Fig. 2. Composite Video

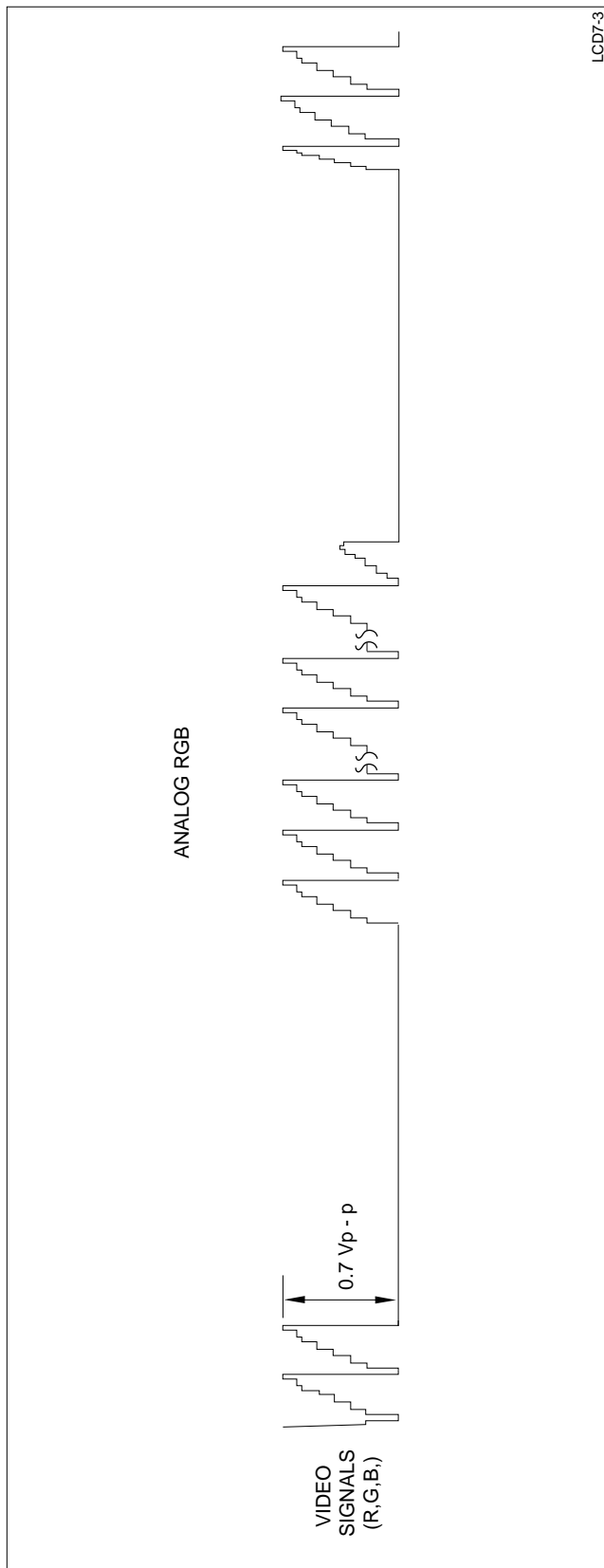

Fig. 3. Analog RGB (non-composite)

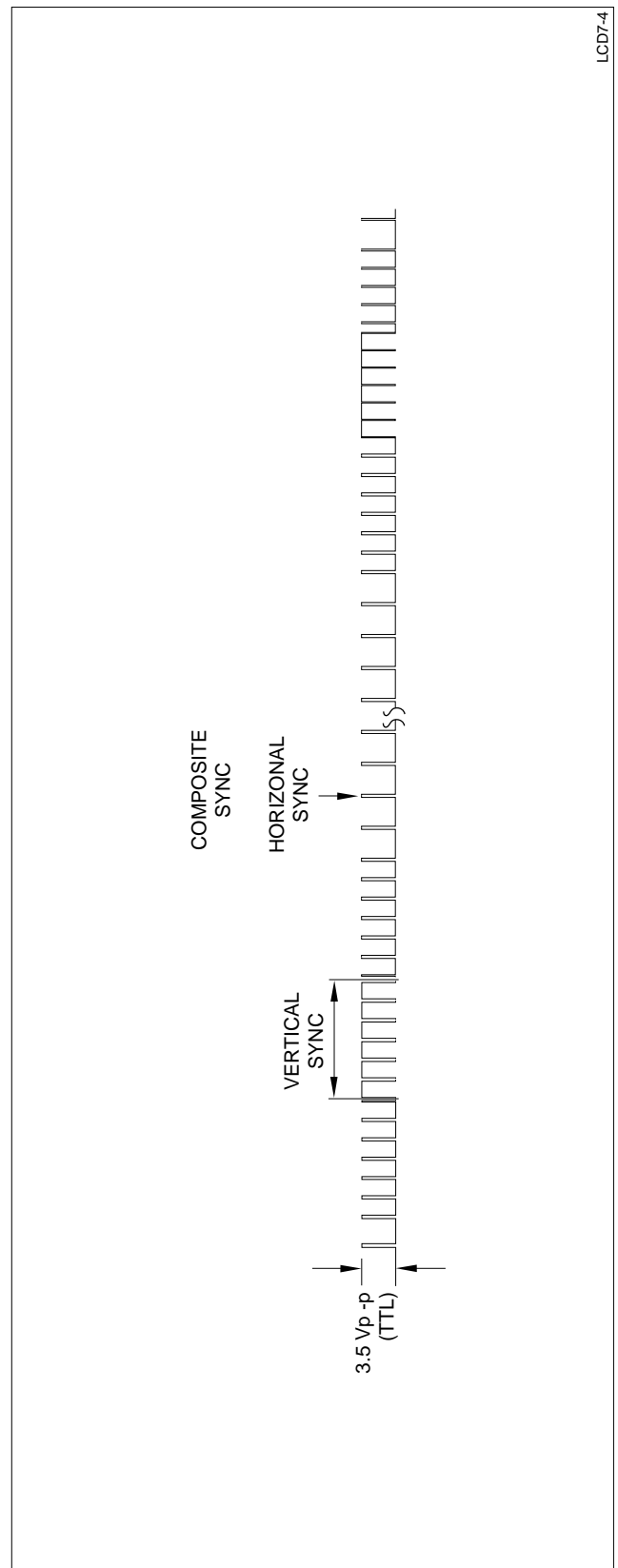

Fig. 4. Composite Sync

GENERAL INFORMATION

Viewing Direction

All 4" and 5.7" color TFT LCD modules are offered with a choice of viewing direction. The last digit of the part number will indicate the viewing direction. A "1" will indicate a 6 o'clock viewing direction while a "2" indicates a 12 o'clock viewing direction. The relationship of the viewing direction optimizes the contrast ratio for +10° to -30° in the vertical axis and the 12 o'clock viewing direction optimizes the contrast ratio for +30° to -10° in the vertical axis (Figure 5). The horizontal viewing angle remains even and consistent for all TFT modules.

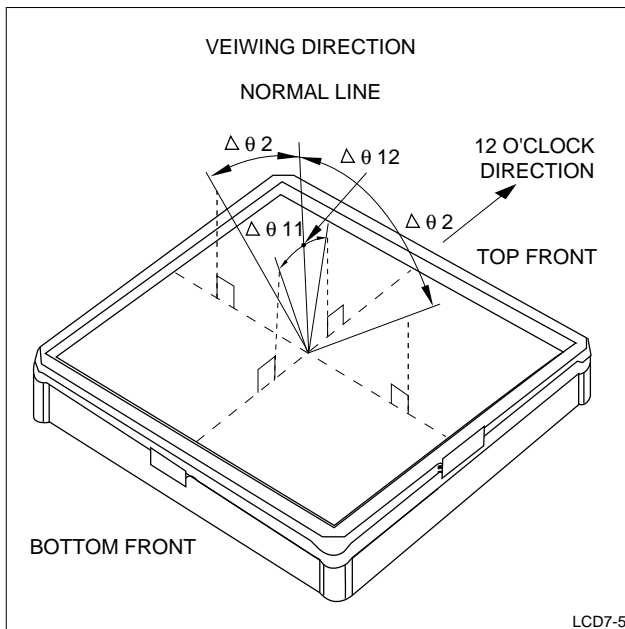

Fig. 5. Viewing Direction

Interlaced Operation

As described earlier, NTSC and PAL video signals consist of two interlace fields. When these fields are viewed on a monitor by the human eye, they appear as one continuous image. In a CRT monitor, these two fields are interwoven on the screen (Figure 6). In a Sharp TFT LCD there are either 240 or 234 lines printed on the glass depending on the model (Note 2). Since the odd and even fields consist of 240 lines each, the fields are scanned on the same lines of the LCD one after another (Figure 7). As with a CRT, the eye integrates these two fields into one complete frame and the resulting image appears to be a full 480 lines on the LCD.

Displaying the video information on the PAL version of the LCD is more involved. The odd and even fields

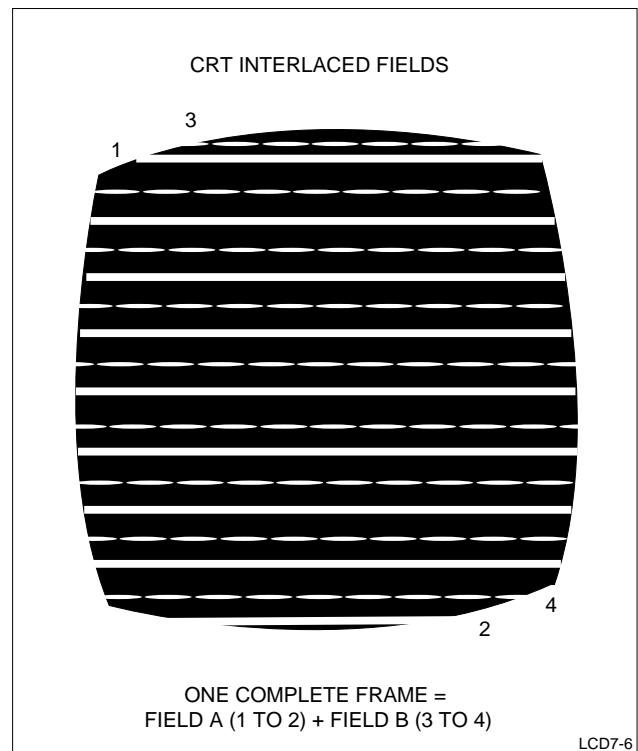

Fig. 6. Interlaced Operation

are made up of 280 lines each. In order to display the information on the 240 line LCD as done in the NTSC mode, the video signal must be reduced to 240 lines/field. This is done by removing 40 lines/field through a method called MBK-PAL (MaBiki "Thinning in Japanese). In this method every seventh line is removed by using the following algorithm (Figure 8):

$$(14n + 11)H, (12n + 19)H \text{ even field}$$

$$(n=1, 2, 3, \dots 20)$$

$$(14n + 16)H, (14n + 22)H \text{ odd field}$$

Pixel Configuration

Each pixel of Sharp's small color TFT LCDs consists of 3 sub-pixels. These red, green, and blue sub-pixels can operate at any output level to give full color capability to each pixel. A 234 V x 382.5 H, 234 V x 479 H or 240 V x 720 H pixel format is available depending on the particular TFT LCD model. The pixel format is defined as the number of sub-pixels (RGB). The actual number of pixels is as follows: 234 V x 128 H (128 x 3 RGB approx. 382.5), 234 V x 160 H (160 x 3 RGB approx. 479), 240 V x 240 H (240 x 3 RGB approx. 720). The LCDs use a delta pixel configuration with each addressable pixel residing on the same line (Figure 9). This configuration makes the LCD displays well suited for video information.

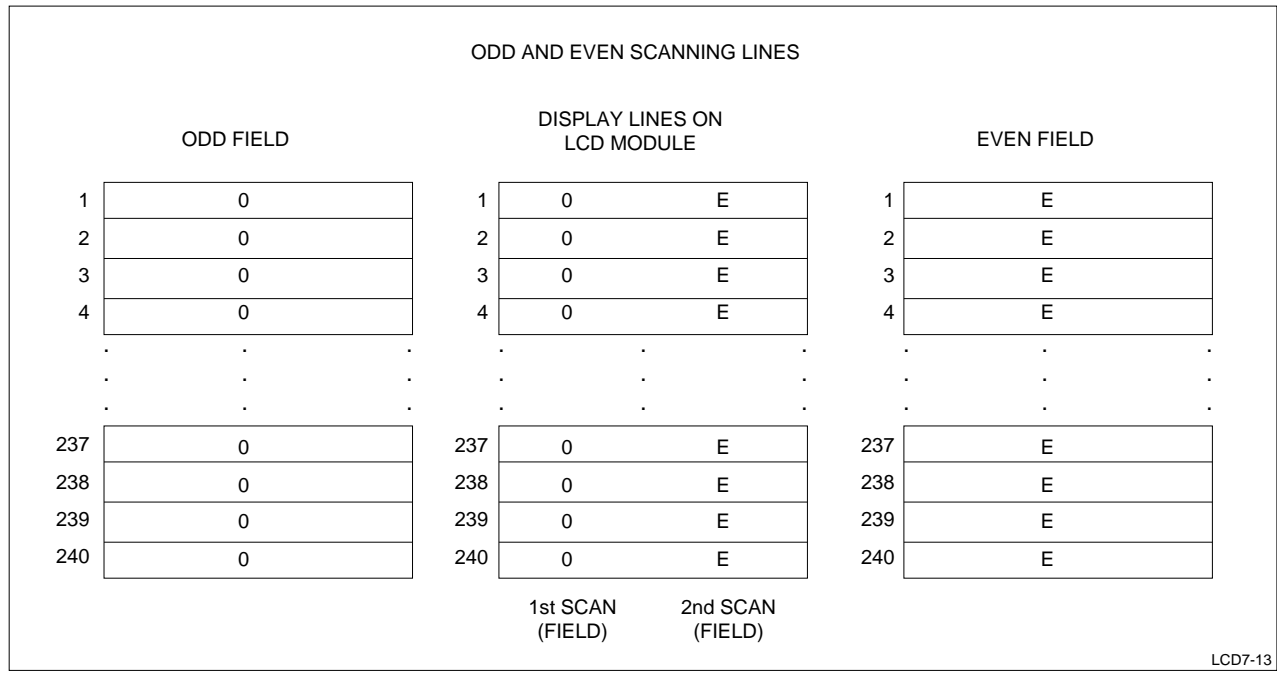

Fig. 7. Odd and Even Scanning Lines

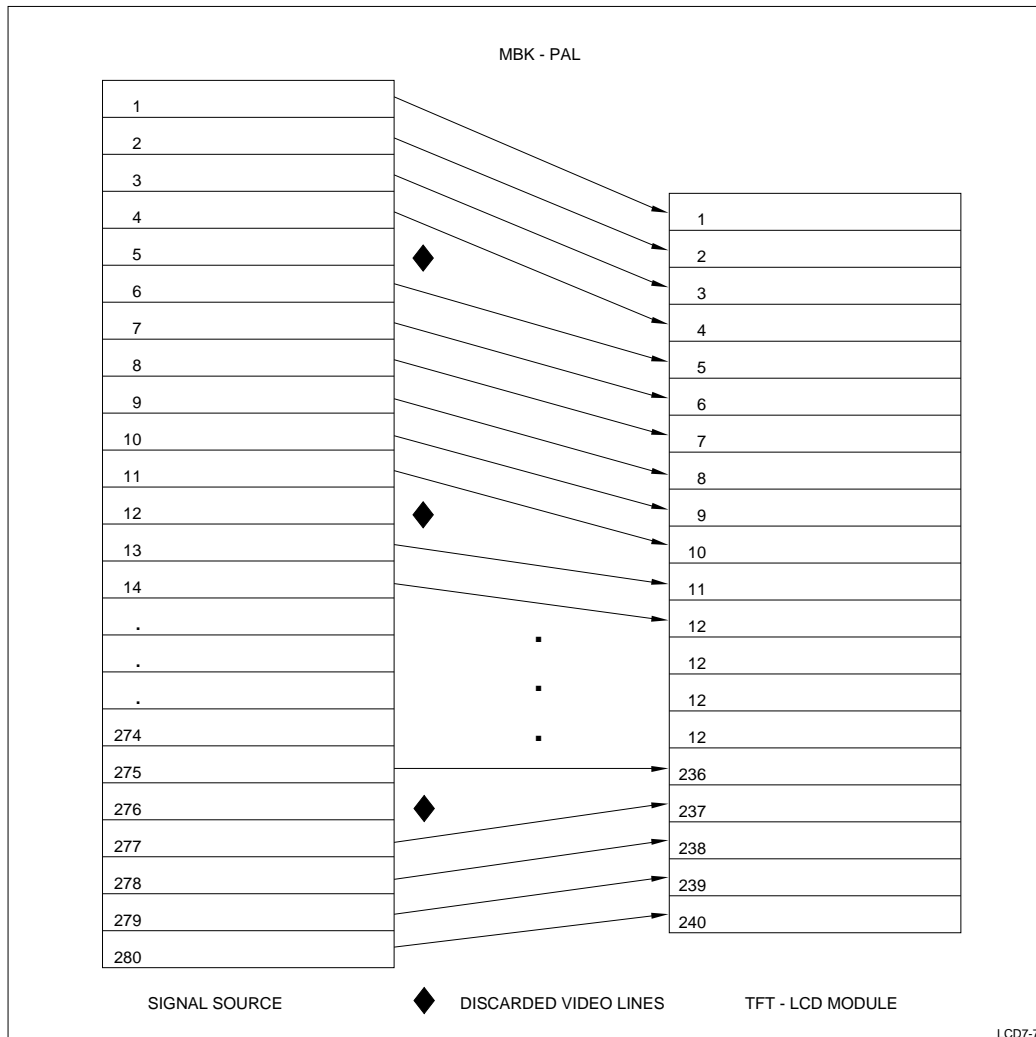

Fig. 8. MBK-PAL Method

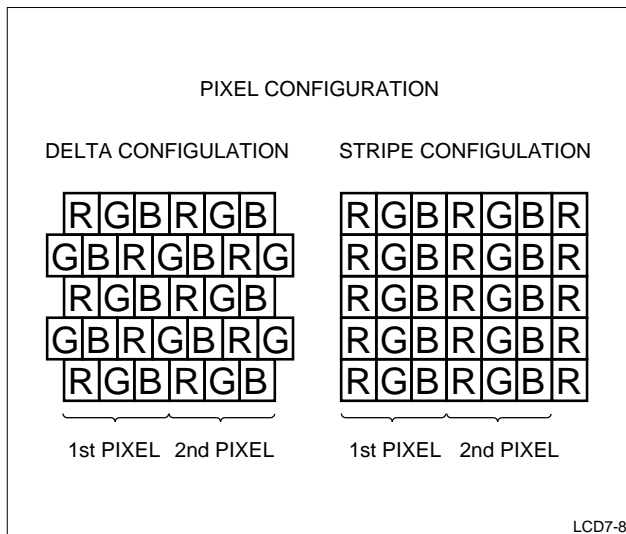

Fig. 9. Delta Pixel Configuration

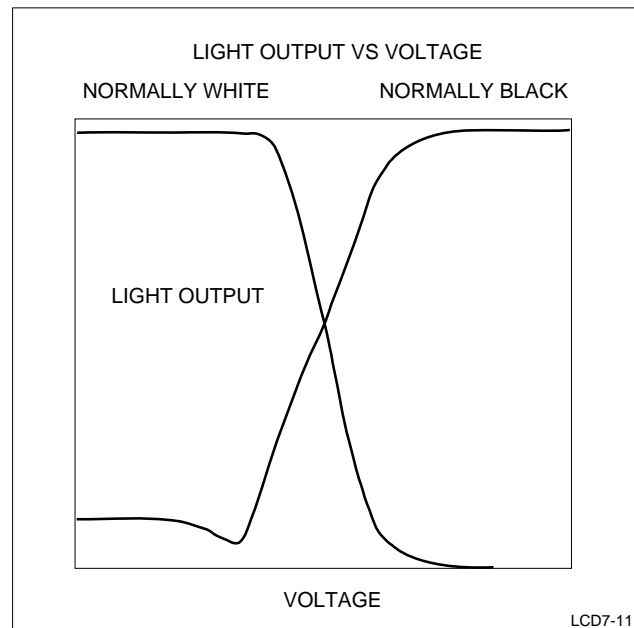

Fig. 10. Light Output vs. Voltage

Normally White Mode

Sharp Color TFT LCD modules operate in the normally white mode. This gives Sharp TFT displays a higher contrast ratio than those using the normally black mode. The main difference between normally white mode and normally black mode is the orientation of the linear polarizers. Normally white polarizers are perpendicular to each other (Figures 11a). When the power is removed in a normally black mode (Figure 11b), the liquid crystal material does a 90° twist. There is still some light at low voltages that will pass through in this configuration (Figure 10). The normally white mode will not let this light through in the off state due to the perpendicular arrangement of the polarizers.

Note 2: The LCD models which have 234 lines drop the last 6 lines in each field to accept the 240 line NTSC input.

Gamma Correction

Gamma correction refers to the exponential variation in the signal input to provide a linear transfer function from the signal source to the display-luminance output. The luminous output of the LCD is not directly proportional to the display-signal input under normal conditions. This is due to the characteristics of the LC material. A similar condition occurs in a CRT

monitor where the luminous output of the phosphors are not directly proportional to the signal input. In order to compensate for this non-linear response, a gamma correction is applied to the monitor (LCD or CRT) to give a linear luminous output (figure 16). Although values vary among monitors, the gamma correction factor for Sharp LCDs is 2.2. This is the same as the accepted value for most CRT monitors.

Gamma is defined as the power exponent used to approximate the curve of display-luminance output versus signal input amplitude. When using a factor of 2.2, for example, a 50% - of-full-scale input voltage will result in a 22%-of-full-scale luminous output ($0.5/2.2 = 0.22$).

All Sharp small color TFT modules have the gamma correction built into the module with the exception of LQ323Y11/P07 and LQ4RE01/2. Sharp's basic design policy is all color TFT LCDs without built-in interfaces will have to be supplied with an external gamma correction, whereas all color TFT LCDs with a built-in interface do not need an external gamma correction.

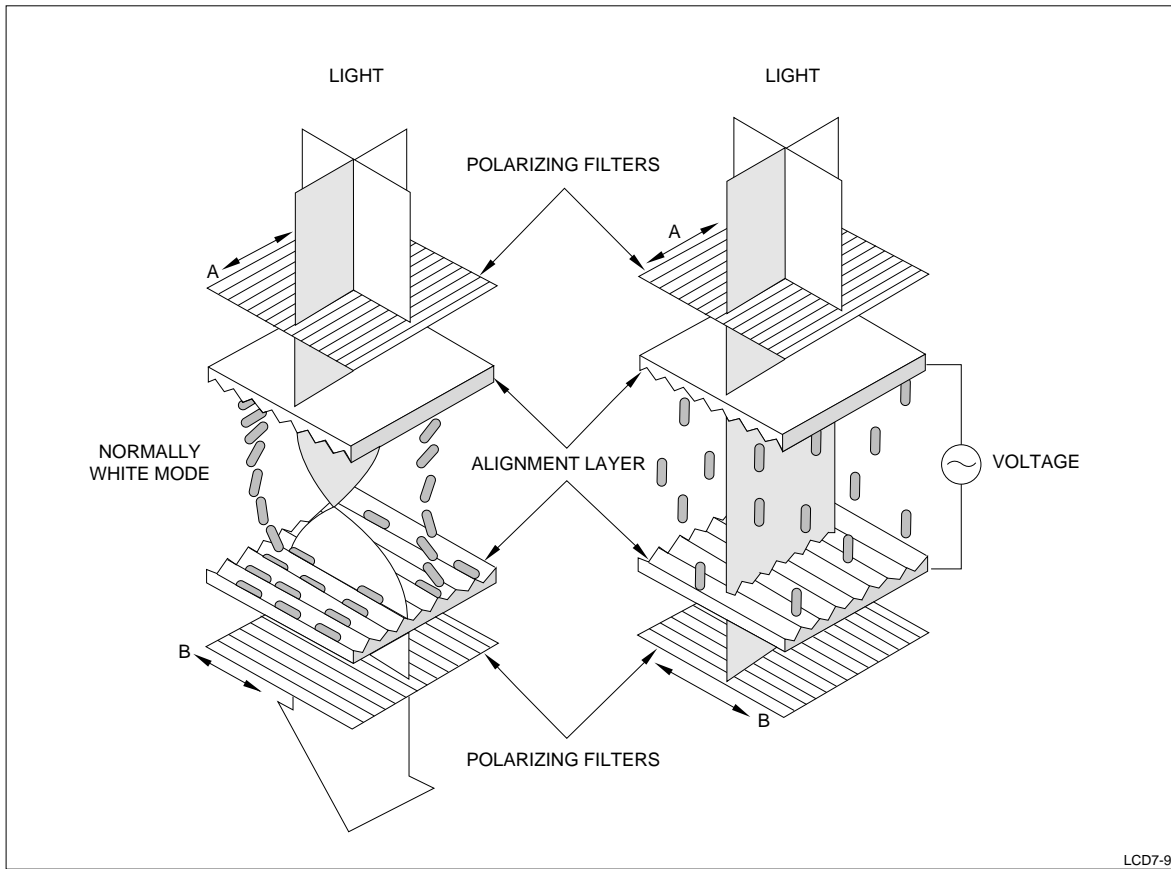

Fig. 11a. Normally White Mode

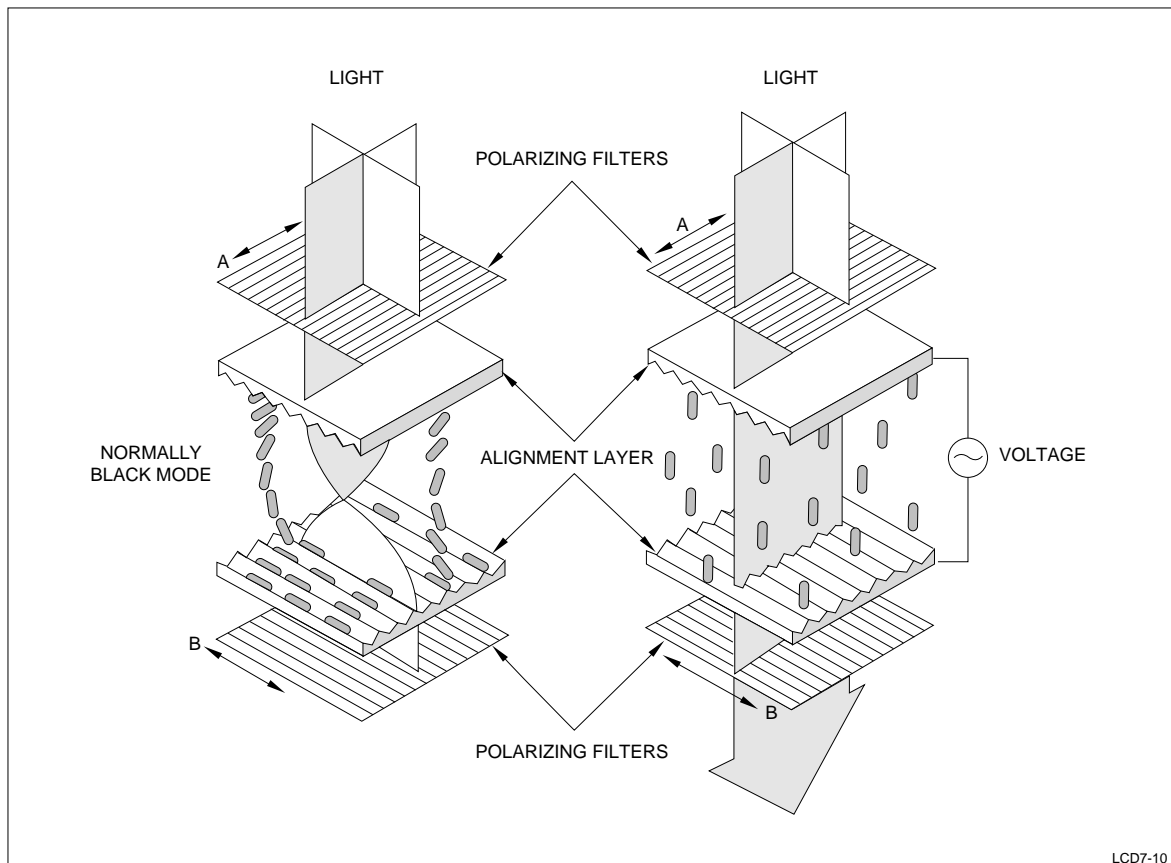

Fig. 11b. Normally Black Mode

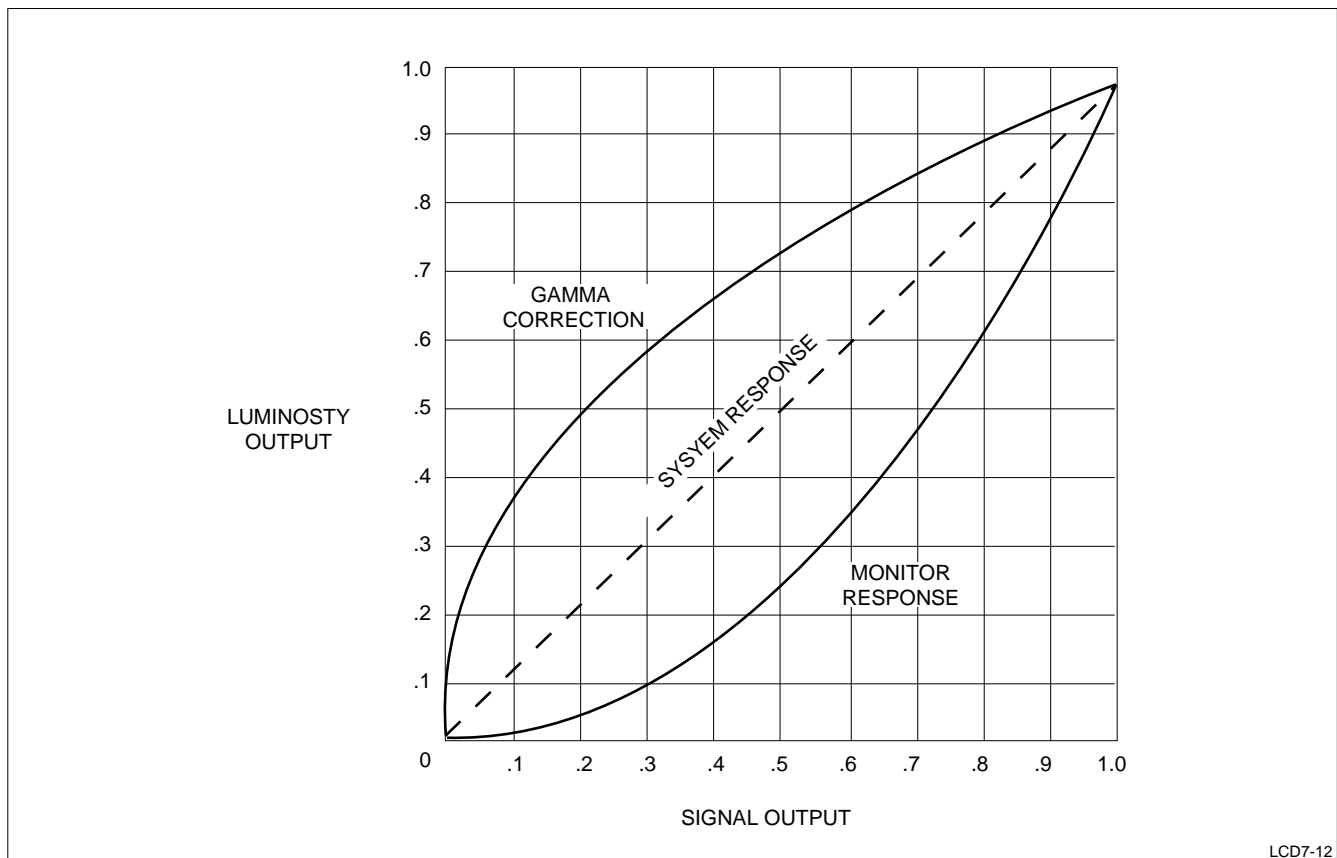

Fig. 12. Linear Luminous Output

Connectors

All the TFT modules use Flat Printed Circuit (FPC) cables and connectors for signal I/O connection. The various modules come with either 16 or 20 conductor cables/connectors with a 1.0 mm or 1.25 mm pitch. Refer to Table 5 for the configuration with each model. The 1.0 mm and 1.25 mm Pitch FPC cables/connectors can be obtained from various companies including the following:

- ELCO (Laguna Hills, CA, 714-830-8383)
1.00 mm/1.25 mm FPC connectors

- Molex (Lisle, IL, 708-969-4550)
1.0 mm/1.25 mm FPC connectors
- Parlex (Salem, NH 603-893-0040)
1.0 mm/1.25 mm FPC cables, custom cables with connectors
- Sumitomo (Freehold, NJ, 908-409-3990)
1.00 mm/1.25 mm FPC cables/connectors.

All the LCD module connectors/cables, along with their mating connectors/cables, are referenced in their individual specifications.

Table 5.
COLOR TFT LCD PRODUCTS THAT REQUIRE MATING FLEX CIRCUIT CABLES

DISPLAY MODEL	CONNECTOR/CABLE ON LCD	MATING CONNECTOR/CABLE
LQ323Y11	16 Conductor FPC Cable; 1.0 mm pitch	16 Conductor FPC Connector; 1.0 mm pitch
LQ323P07	16 Conductor FPC Cable; 1.0 mm pitch	16 Conductor FPC Connector; 1.0 mm pitch
LQ4RE01/2	16 Conductor FPC Cable; 1.0 mm pitch	16 Conductor FPC Connector; 1.0 mm pitch
LQ4RA01/2	20 Conductor FPC Connector; 1.25 mm pitch	20 Conductor FPC cable; 1.25 mm pitch
LQ4NC01/2	20 Conductor FPC Connector; 1.0 mm pitch	20 Conductor FPC Cable; 1.0 mm pitch
LQ4RB03	16 Conductor FPC Connector; 1.0 mm pitch	16 Conductor FPC Cable; 1.0 mm pitch
LQ4RB11	16 Conductor FPC Connector; 1.0 mm pitch	16 Conductor FPC Cable; 1.0 mm pitch
LQ6RA01/2	20 Conductor FPC Connector; 1.25 mm pitch	20 Conductor FPC cable; 1.25 mm pitch
LQ6NC01/2	20 Conductor FPC Connector; 1.0 mm pitch	20 Conductor FPC Cable; 1.0 mm pitch

Backlight

The backlight on the 4" and 5.7" TFT LCD modules is replaceable. The replacement backlight modules can be obtained from Sharp as needed. The backlight on the 4" modules uses HCFTs (hot cathode fluorescent tubes) and on the 6" modules the backlight uses CCFTs (cold cathode fluorescent tubes). The main differences between the two technologies are: 1) HCFTs have to pre-heat the filament, 2) HCFTs tend to have a higher light output, and 3) HCFTs will have a shorter life.

The Sharp part number for the 4" replacement backlight module is LQ0B01 and the part number for the 6" replacement module is LQ0B04.

The input for backlight modules varies from 110 Vrms @20-50 kHz for the HCFT modules to 330 Vrms @20-50 kHz for the CCFT modules. These modules also require an ignition voltage of 600 - 800 Vrms for initial discharge of the backlight tubes.

Inverters to drive these voltages are presently available from Sharp and also from Endicott Research Group, Endicott, NY (607-754-9187). These inverters usually run off an input of either +5 V, +12 V or +24 V DC. The Sharp part numbers for the inverters are LQ0J06 for the 4" modules and LQ0J04 for the 6" modules. The LQ0J06 comes with an input voltage connector and two output cable assemblies to connect directly to the backlight module. The LQ0J04 also

comes with an input voltage connector, but can connect directly to the backlight module without cables.

Handling/Cleaning

The face of the Color TFT LCD modules consists of an outer polarizer. The polarizer is made from a soft material and care should be taken not to scratch this surface. Any scratch to the surface will adversely affect the operation and quality of the display. All mounting configurations should include some type of clear protective covering to prevent any damage to the polarizer and module. The protective laminate, shipped with the module, should only be removed immediately before the protective covering is placed in front of the face of the module.

If some dust happens to get on the surface of the display, it should be blown off with an ionized air gun to prevent any static build-up of dust. Wiping the unit with a cloth will scratch and damage the polarizer. If, in the worst case, dirt or a smudge appears on the glass, Sharp recommends using a soft, dry cloth with a very small amount of petroleum benzene.

As with any LCD display, do not expose the display to prolonged direct sunlight/UV rays as the filters and LC material will degrade over time. A clear protective antiglare filter that also filters UV may provide the best all-around solution to protect the LCD from the environment.

INTERFACING TO THE DISPLAY MODULE

Interfacing to the various modules varies from model to model. Each model will be examined and their interfacing requirements defined.

LQ323Y11/P07

These two display modules support either NTSC (LQ323Y11) or PAL (LQ323P07) video standards. They require an external interface to control the input data and sync signals, along with an external backlight. DC input voltages of +5.0 V, +13.0 V, -8.0 V and -20.0 V also must be provided. To prevent damage to the LCD, the power voltages to the source and gate drivers must be applied in the following power on/off sequence:

On: +5.0 V-->+13.0 V-->-20.0 V-->-8.0 V

Off: -8.0 V-->-20.0 V-->+13.0 V-->+5.0 V

Separate RGB video signals, alternating in polarity, must be used to input the data. The FRP signal output (TTL level clock signal = 1/2 horizontal sync frequency) should be combined with the RGB video signals to give the alternating video inputs. The alternating video signals prevent electrochemical degradation of the LC material which can be caused by applying either all negative or all positive voltages.

Composite horizontal and vertical sync is also required as an input to these units. A separate horizontal and vertical sync output from the module can be used to sync video overlays on the screen.

Vcom (common electrode driving signal) is a required clock signal, in phase with the alternating video signal, which controls the amplitude of the video signal. Controlling the amplitude of this signal will control the contrast of the LCD module.

These displays can be easily controlled by using one of Sharp's interface ICs for LCDs. These interface ICs have onboard gamma correction and polarity inversion among other useful features. The IR3P89 is a general purpose color LCD interface IC which processes RGB video into RGB signals suitable for input into the LCD module. This part only performs basic functions and does not have any chroma processing capabilities. The IR3P90B (NTSC) and IR3P96 (PAL) can accept either a composite video input or separate RGB input and has the capability of performing extensive video/chroma processing. Depending on the application, one of these ICs will be able to efficiently fulfill the 3" TFT LCD interface requirements.

There are only two adjustments available to modify the visual performance of the modules. Vcom, as described earlier, is an input signal that will change the display contrast. H-POS is an adjustment on the module that can readjust the image if it is not centered horizontally. All other controls are preset during pro-

duction and should not be adjusted by the user to maintain optimum performance of the module.

LQ4RE01/2

These modules accept either NTSC or PAL video inputs by changing the TTL level of the mode change terminal. An external backlight along with a series of input voltages and processing signals are required to drive these units. The input DC supply voltages required are +5.0 V, +13.0 V, -8.0 V and -20.0 V. These voltages supply the power for the source and gate drivers and should be applied in the following power on/off sequence:

On +5.0 V-->+13.0 V-->-20.0 V-->-8.0 V

Off -8.0 V-->-20.0 V-->+13.0 V-->+5.0 V

The video input signals required are composite sync along with separate RGB signals alternating in polarity by using the FRP output signal. The FRP signal is a TTL level clock signal operating at 1/2 the horizontal sync frequency. The FRP signal when combined with the analog video signal should give a combined alternating signal of 5 Vp-p. The polarity of the video signal must be alternated to prevent the LC material from electro chemical degradation.

As with the 3" modules, Sharp interface chips IR3P89, IR3P90B and IR3P96 can be used on the LQ4RE01/2 models to perform the required processing of the interface signals.

Horizontal and vertical sync are also available as outputs to synchronize video overlays on the screen such as time/channel indication for a TV application.

There are a series of adjustments that can be used to adjust the visual characteristics of the LCD. Vcdc (common electrode driving signal) is a DC bias input that can be used to optimize the contrast of the display. This adjustment is optimized during manufacturing and should not be readjusted by the user under normal operating conditions. If operating conditions change, such as a reduction in the input power voltage level, Vcdc can be readjusted to optimize the performance of the display module by using the adjustment method described in the TFT-LCD module specification. The H-Pos (horizontal position) control on the module can adjust the position of the picture on the display. All other controls are preset at the factory and should not be touched in order to assure optimum performance.

LQ4RA01/2, LQ6RA01/2

These 4" and 5.7" modules are compatible with both NTSC and PAL Video standards. The replaceable backlight is already incorporated into these units and the user need only supply a DC-AC inverter to power the backlight. The video section requires DC power supply voltages of +5.0 V and -8.0 V applied in the following power on/off sequence:

On +5.0 V-->-8.0 V

Off -8.0 V-->+5.0 V

The video drive signals consist of composite sync and separate RGB analog video signals. The sync accepts a standard composite sync signal or a standard composite video input (1.0 Vp-p). The video inputs consist of separate (3) RGB analog signals (0.7 Vp-p). There are two sets of video RGB inputs that can be multiplexed by a TTL control signal (VSW) for displaying two separate video sources. The horizontal and vertical sync outputs can be used to synchronize overlays on the display an might be done in a television application.

As with all of the color TFT LCD modules, there are adjustments to control the display visual characteristics. Brightness (BRT) and contrast (Vcdc) can be adjusted by changing the DC voltage to these two inputs. For optimum performance Sharp recommends not readjusting Vcdc under normal operating conditions. There are also a number of adjustments on the back of the module. Most of these have been adjusted at the factory for optimum performance and display quality. The adjustments that are user accessible are contrast, brightness and horizontal position. The contrast (Vcdc) and brightness adjustments as indicated, can be adjusted either externally or on the module itself.

LQ4NC01/2, LQ6NC01/2, LQ6MC01/2

This series of 4" and 5.7" modules operates from a composite video input. The "N" series is compatible with a NTSC input and the "M" series is compatible with a PAL input. The backlight is in a modular form and can be easily replaced.

The video section requires a DC power supply of +5.0 V and -6.0 V to be powered on/off simultaneously. As with all of the modules, the video signals should be applied after the supply voltages. The video input signals consist of a composite video input along with separate (3) RGB analog video inputs. The separate RGB video inputs synchronized with the horizontal and vertical sync outputs can be multiplexed with the composite video input to give onscreen overlapping images.

The demodulation of the color burst is performed internal to the module and the color gain (COL) and tint (TIN) can be adjusted either on the back of the

module or external to the module by changing the DC input voltage. Contrast and brightness may also be adjusted on the module or externally. The horizontal position control on the back of the module can be used to center the image, but all other adjustments on the back of the module are performed at the factory and should be left alone for optimum operation of the module.

CONCLUSION

Sharp will also be introducing a series of new small TFT color LCD modules. The LQ4RB03 will have a similar interface to the LQ4RE01, but will include the backlight module and come in a slightly more compact package. The LQ4RB11 and LQ6RB11 are 4" and 5.7" LCDs that will also be similar to the LQ4RE01 interface, but will have an optional backlight module and a lower resolution. These units will be targeted toward more cost sensitive applications.

Sharp is also working on increasing the temperature range of the TFT color modules. Sharp's initial goal is to introduce units with a storage temperature of -30° C to +80° C and an operating temperature of -10° C to +70° C. By 1993 Sharp plans to have units available with the capability of a storage temperature of -30° C to +90° C and an operating temperature of -30° C to +85° C. Sharp's efforts to fulfill these goals will concentrate on all aspects of the LCD module: driver/interface ICs, interconnect technology, backlighting technology, polarizer technology, and the LC glass structure itself. Sharp is very confident it can meet the demand for modules which are subject to severe environmental conditions.

With a variety of models available, Sharp's small TFT color LCD modules can meet the design requirements needed for compact monitor applications. The variety of available models also offers a range of cost/performance options. The realm of applications is only limited by the imagination of the designer.

REFERENCES

Raster Graphics Handbook. Second Edition. Conrac Division, Conrac Corporation. New York: Van Nostrand Reinhold Company. 1985.

TV/Video Sync: Primer and Product Note Opt. 005-1. Hewlett/Packard. November, 1981.

NOTES

LIFE SUPPORT POLICY

SHARP components should not be used in medical devices with life support functions or in safety equipment (or similar applications where component failure would result in loss of life or physical harm) without the written approval of an officer of the Sharp Corporation.

SHARP reserves the right to make changes in specifications at any time and without notice. SHARP does not assume any responsibility for the use of any circuitry described; no circuit patent licenses are implied.

SHARP**NORTH AMERICA**

SHARP Electronics Corporation
Microelectronics Group
5700 NW Pacific Rim Blvd., M/S 20
Camas, WA 98607, U.S.A.
Phone: (360) 834-2500
Telex: 49608472 (SHARPCAM)
Facsimile: (360) 834-8903

EUROPE

SHARP Electronics (Europe) GmbH
Microelectronics Division
Sonninstraße 3
20097 Hamburg, Germany
Phone: (49) 40 2376-2286
Telex: 2161867 (HEEG D)
Facsimile: (49) 40 2376-2232

ASIA

SHARP Corporation
Integrated Circuits Group
1, 2613-banchi, Ichinomoto-cho
Tenri-shi, Nara Pref. 632, Japan
Phone: (07436) 5-1321
Telex: LABOMETA-B J63428
Facsimile: (07436) 5-1532